



ME 328: Medical Robotics
Winter 2019

Lecture 15: Rehabilitation (movement therapy) robots

Allison Okamura
Stanford University

some of this material is courtesy Machiel van der Loos

U.S. Demographics of Potential Therapy Robot Users

- **Stroke:**
 - 800,000 cases per year (incidence)
- **Cerebral palsy:**
 - 300,000 - 500,000 prevalence
 - 8,000 incidence
- **Orthopedic interventions:**
 - Post knee & hip replacement exercise
 - Ankle surgery
 - Trauma

Stroke Rehabilitation Strategies

- Important variables in optimal rehabilitation
 - Quantity
 - Duration
 - Intensity/repetition
 - Task-specific
- Robotic control strategies
 - Assisting movement
 - Challenging movement
 - Simulating normal tasks
 - Non-contact coaching

D. Jack et al. Virtual Reality-Enhanced Stroke Rehabilitation. *Neural Systems and Rehabilitative Engineering*, 9(3): 308-318, 2001.

L. Marchal-Crespo et al. Review of control strategies for robotic movement training after neurologic injury. *Journal of NeuroEngineering and Rehabilitation*, 6(20): 2009.

Research Phases in Robot-Assisted Stroke Therapy

1. Replicating the therapist
2. Augmenting the therapist
3. Designing the super-therapist
4. Enabling the inner therapist

Phase I:
Replicating the therapist

MIME: Mirror-Image Movement Enabler (PA VA/Stanford)

Robotic system assisting upper limb neuro-rehabilitation



Facilitates paretic elbow and shoulder movement

Four modes of exercise:

- Passive
- Active-Assisted
- Active-Resisted
- **Bimanual**

C.G. Burgar, P.S. Lum, P.C. Shor, H.F.M. Van der Loos, Development of robots for rehabilitation therapy: the Palo Alto VA/Stanford experience, *Journal of Rehabilitation R&D*, Vol. 37, No.6, November/December, 2000, 663-673.

P.S. Lum, C.G. Burgar, P.C. Shor, M. Majmundar, H.F.M. Van der Loos, Robot-assisted movement training compared with conventional therapy techniques for the rehabilitation of upper limb motor function after stroke, *Archives of PM&R*, vol. 83, 2002, 952-959.

MIT-MANUS, now InMotion (MIT)

Statistically significant improvement in Fugl-Meyer and clinical strength scales after 4-week regimen of daily 1-hour sessions.



Krebs et al. Increasing Productivity and Quality of Care: Robot-Aided Neurorehabilitation, *VA Journal of Rehabilitation Research and Development* 37:6:639-652, 2000.

Fasoli et al. Effects of Robotic Therapy on Motor Impairment and Recovery in Chronic Stroke, *Arch. Phys. Medic. Rehab.* 84:477-482, 2003.

ARM Guide (Rehab Institute of Chicago)

Linear slide with motor
6-dof force sensing

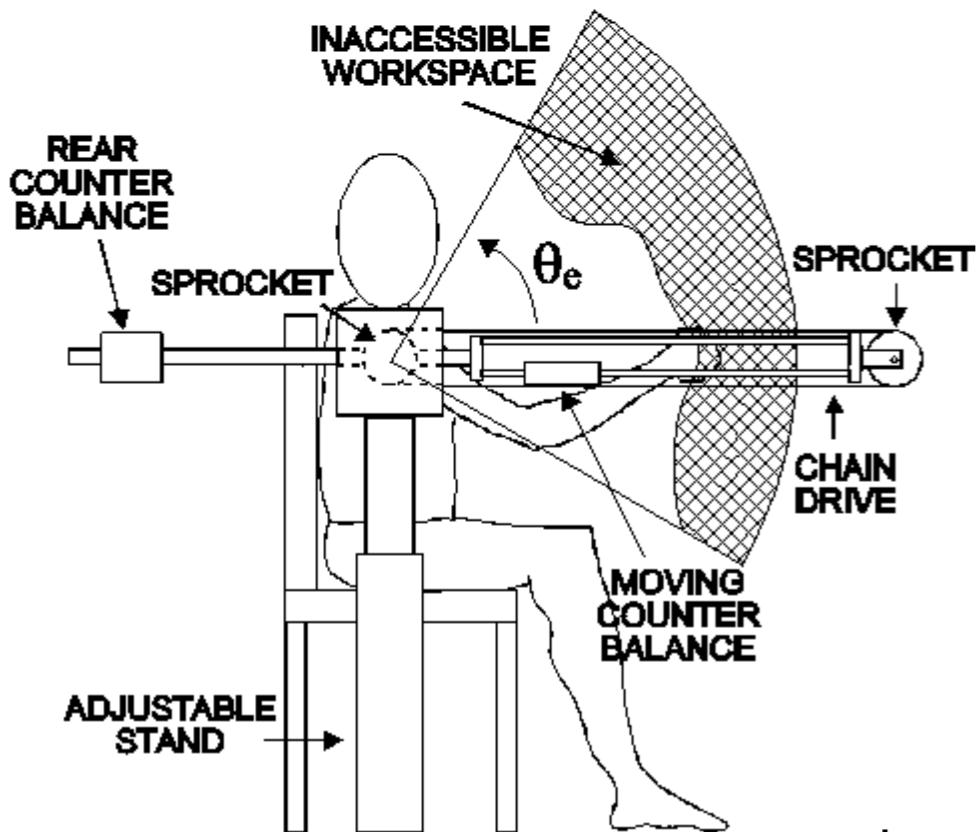
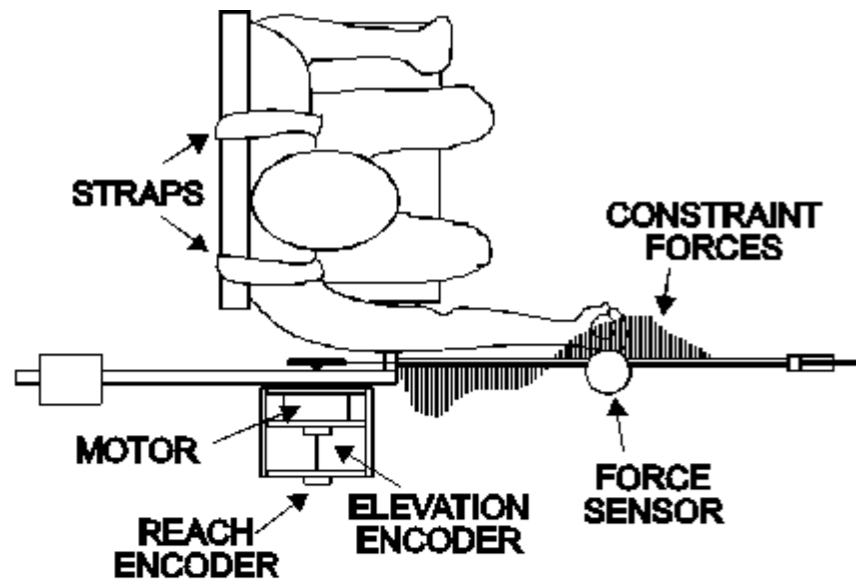

Phase 2: Augmenting the therapist

Driver's SEAT (PA VA/Stanford)

An upper limb one-degree-of-freedom robotic therapy device that incorporates a modified PC-based driving simulator.

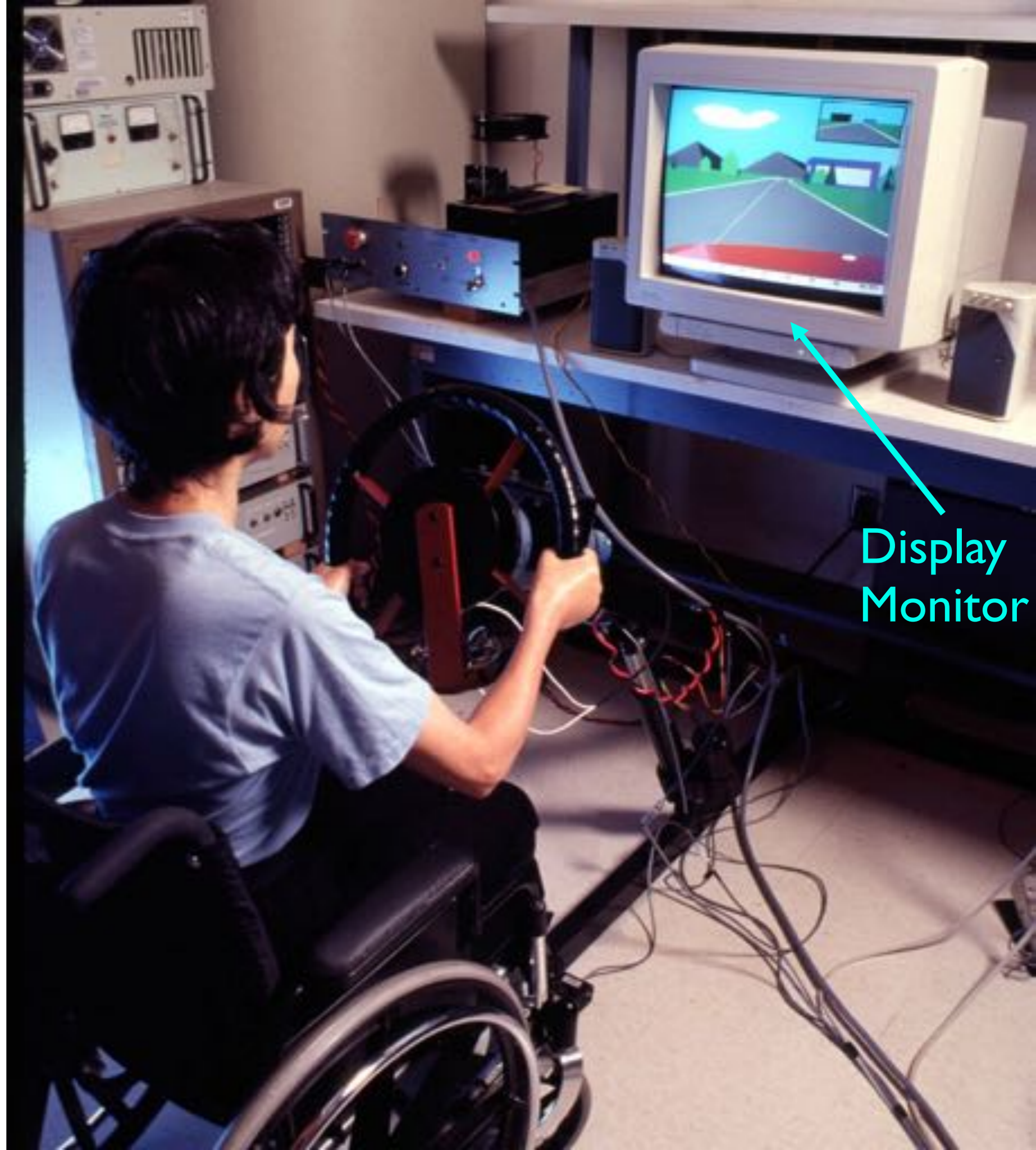

Display
Monitor

Split Steering Wheel

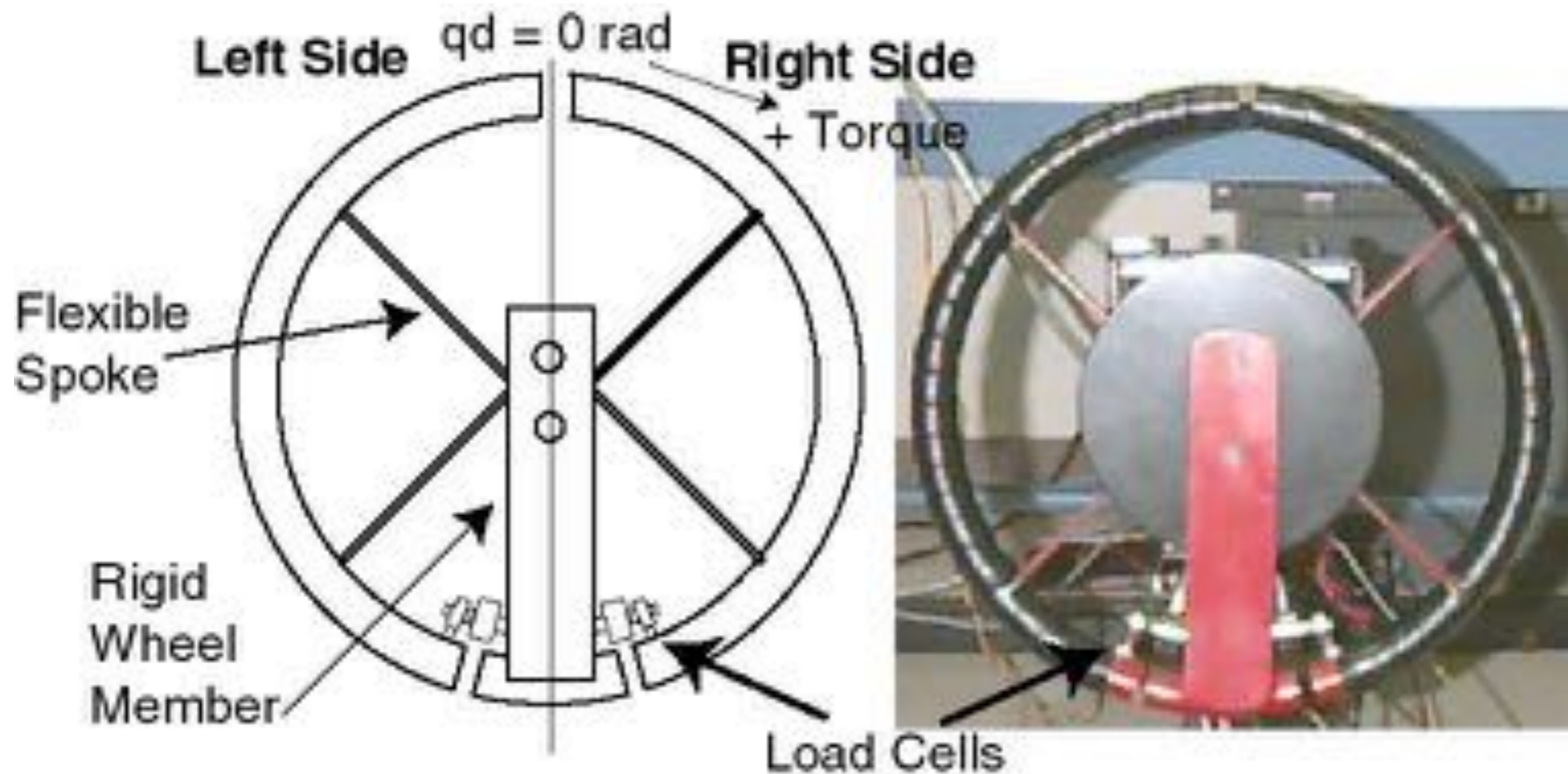

M.J. Johnson, H.F.M. Van der Loos, C.G. Burgar, P. Shor, L.J. Leifer, Design and evaluation of Driver's SEAT: A car steering simulation environment for upper limb stroke therapy. *Robotica*, Volume 21, Issue 01, January 2003, pp. 13-23.

M.J. Johnson, H.F.M. Van der Loos, C.G. Burgar, P. Shor, L.J. Leifer, Experimental results using force-feedback cueing in robot-assisted stroke therapy, *IEEE Transactions on Neural Systems and Rehabilitation Engineering* 13:3, Sept. 2005, pp. 335-348.

GENTLE/s (EU project)



P. van de Hel, B.J.F. Driessen, M.P. Oderwald, S. Coote, E. Stokes "Gentle/s: Robot mediated therapy for stroke patients in a virtual world makes exercising more enjoyable and effective," *Assistive technology - added value to the quality of life AAATE'01*, IOS Press Amsterdam C. Marincek et al. pp.256-261 (2001)

Phase 3: Designing the super-therapist

Adding, then Removing Force-Field

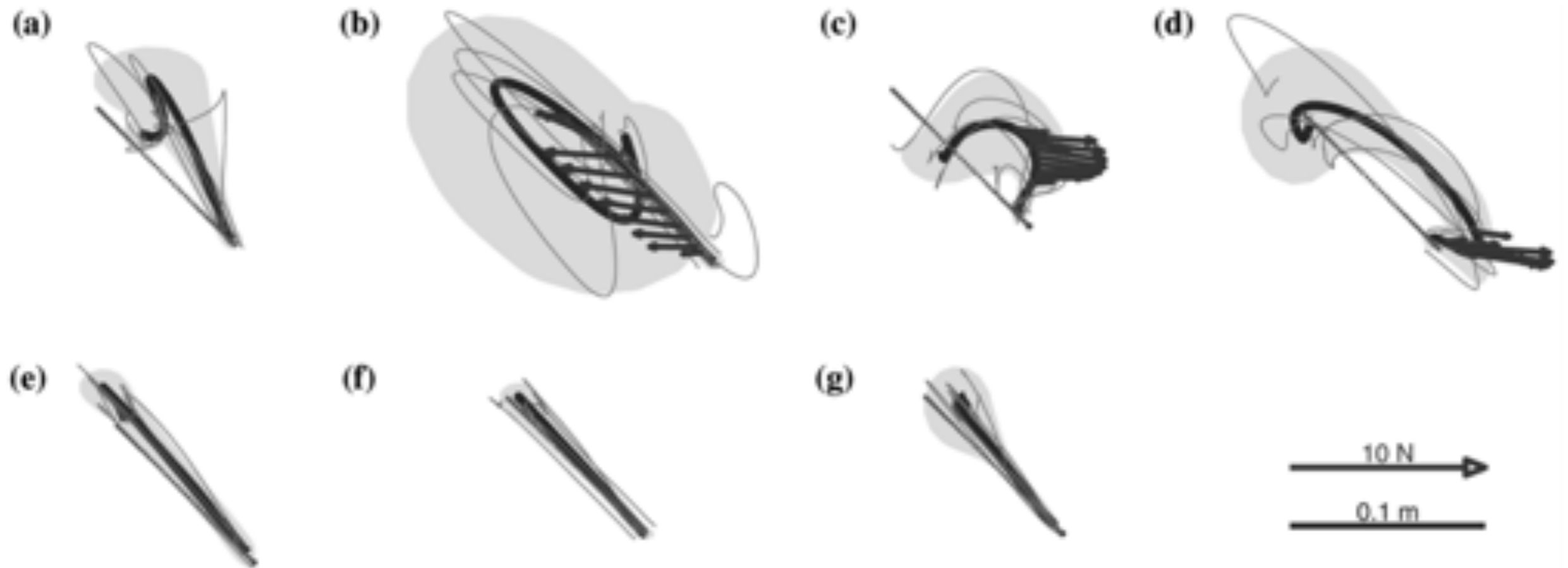

A 315° trajectory from one stroke subject. (a) unperturbed baseline, (b) late machine learning, (c) early training, (d) late training, (e) aftereffects, (f) early washout, and (g) late washout. Desired trajectories are bold dotted lines, average trajectories are bold solid lines, individual trajectories are thin lines, and shaded areas indicate running 95% confidence intervals of ensemble.

'Paris' VR System (Rehab Institute of Chicago)

Goal: Better transfer to Activities of Daily Living

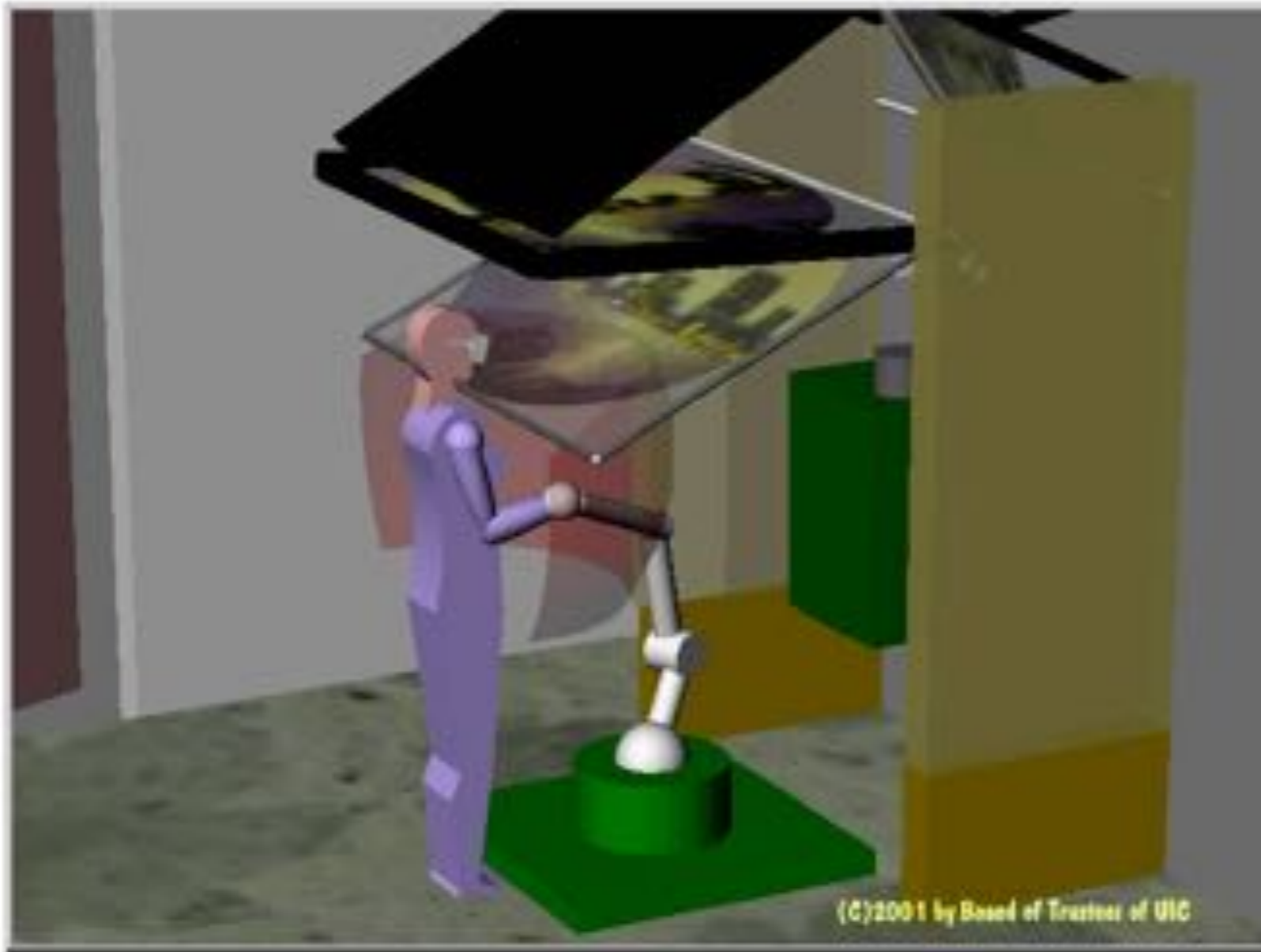

- ◆ 5-axis WAM manipulator
- ◆ Full-arm movement
- ◆ Projection of objects through glass
- ◆ Virtual object manipulation

Phase 4:
Enabling the inner therapist

Using affect to change robot behavior



Kulić, D., Croft, E.A., Affective State Estimation for Human–Robot Interaction, *IEEE Transactions on Robotics*, vol.23, no.5, pp. 991-1000, Oct. 2007.

Liu C, et al. Online Affect Detection and Robot Behavior Adaptation for Intervention of Children With Autism, *IEEE Transactions on Robotics*, vol.24, no.4, 883-896, Aug. 2008.

Novak, D., et al. Psychophysiological Responses to Robotic Rehabilitation Tasks in Stroke, *IEEE Transactions on Neural Systems and Rehabilitation Engineering*, vol.18, no.4, pp. 351-361, Aug. 2010.

Riener, R., et al. Bio-cooperative robotics: controlling mechanical, physiological and mental patient states. Conference Proceedings IEEE 11th International Conference on Rehabilitation Robotics (ICORR 2009), Kyoto, Japan, (2009)

Lower-Extremity Rehabilitation Robots

PAM + ARTHUR walking aid

- Treadmill-based
- Pelvis assist (PAM) + walking assist (ARTHUR)
- PAM: linear actuators to support pelvis
- Linear actuators on rail to provide foot motion assist

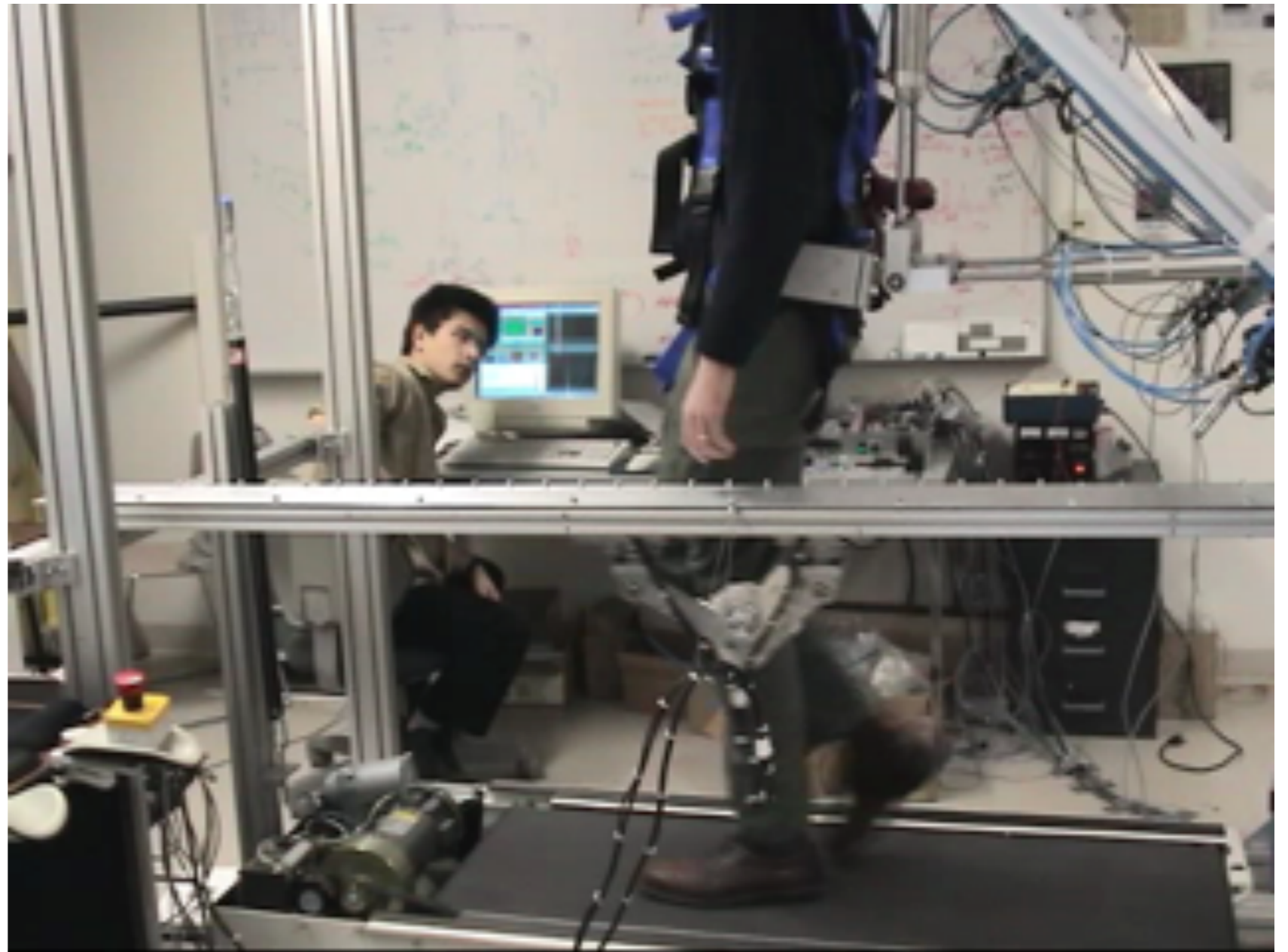

<http://www.eng.uci.edu/~dreinken/Biolab/biolab.htm>

Lokomat Treadmill Walker

- Each side = 2 dof
- Linear actuators
- Supported treadmill walking
- Patients with stroke, iSCI



<http://www.research-projects.unizh.ch/med/unit43000/area198/p1237.htm>

UBC-CARIS Lab Balance Training

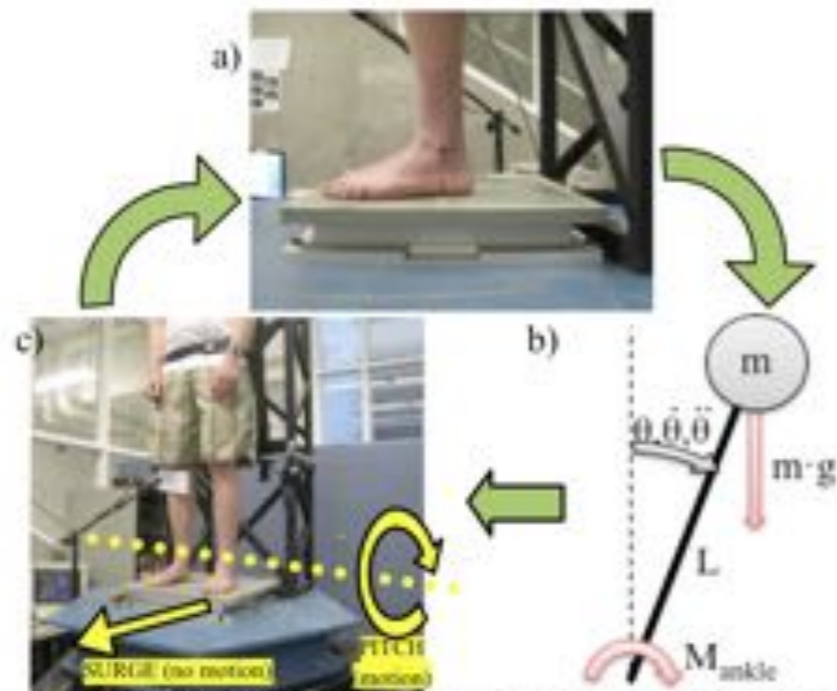

Fig. 1. Control loop for balance simulator (clockwise from top): a) forceplate measures ankle torque applied by subject; b) a computer calculates motion and position of an inverted pendulum with the same torque applied; c) the motion platform moves in pitch direction to match the position of the inverted pendulum; control loop repeats as subject moves with platform and adjusts ankle torque.



B. Luu, T. Huryn, E.A. Croft, H.F.M. Van der Loos, J.-S. Blouin, Investigating load stiffness in quiet stance using a robotic balance system, *IEEE TNSRE*, Apr. 2011.

T.P. Huryn, B.L. Luu, H.F.M. Van der Loos, J.-S. Blouin, E.A. Croft, Investigating human balance using a robotic motion platform, *Proceedings IEEE-ICRA 2010*, Anchorage, AL, May, 2010.

Robots for Neuroscience

Predicting and Correcting Ataxia Using a Model of Cerebellar Function and an Exoskeleton Robot



In collaboration with Nasir Bhanpuri and Amy Bastian
Supported by NIH grants/fellowships R21-NS061189,
R01-HD040289, F31-NS070512, F31-NS061613



Kennedy Krieger Institute

Aim of rehabilitation robotics

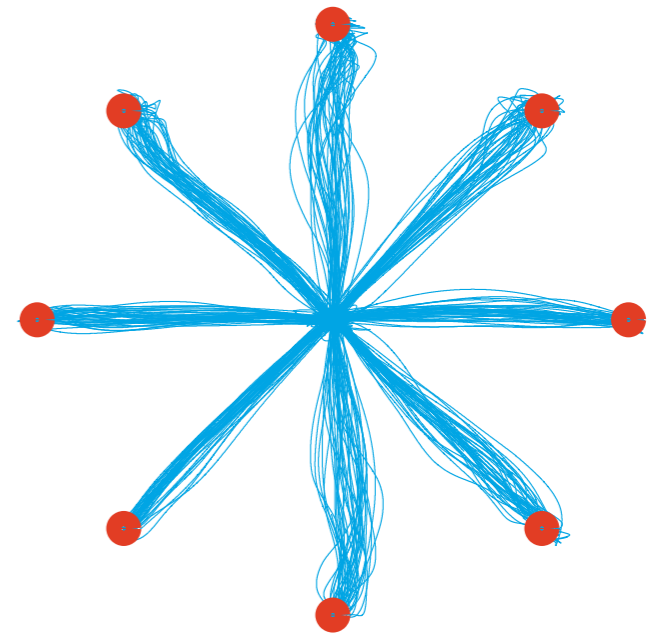
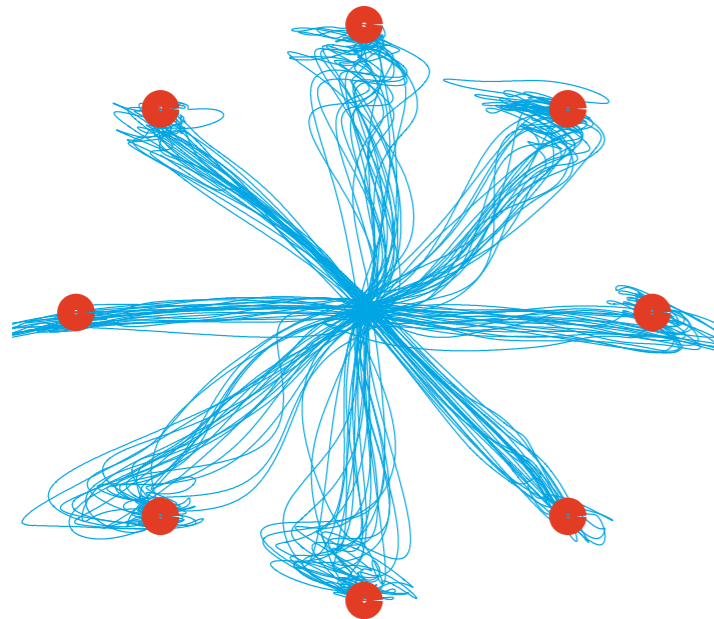

and...

Transfer to activities of daily living
At-home rehabilitation or orthotics
Want *learning* or *correction*, not strategies

We need models of patient deficits!

Motion Incoordination: Cerebellar Ataxia



Control
(Healthy)

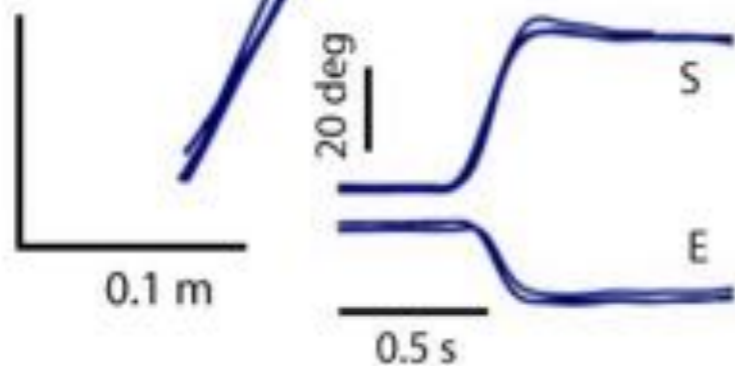

Cerebellar

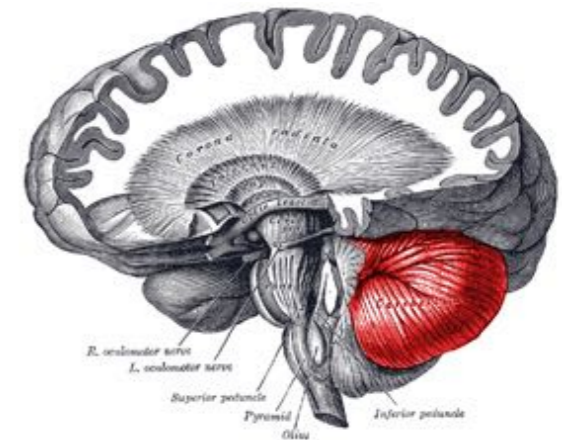

Cerebellar Patient



Exoskeleton robot

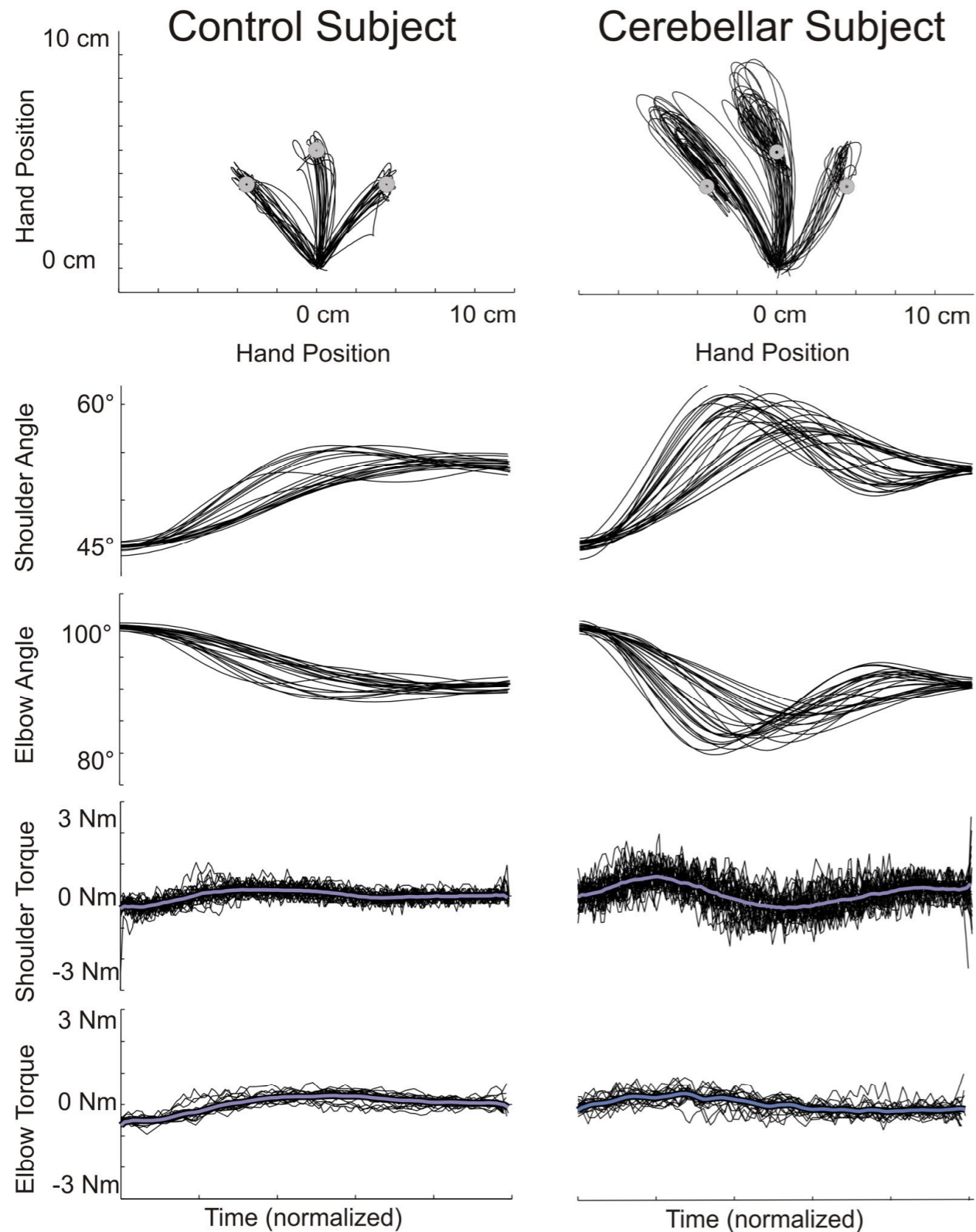

Single-jointed reaching: reaching: Arm flexion

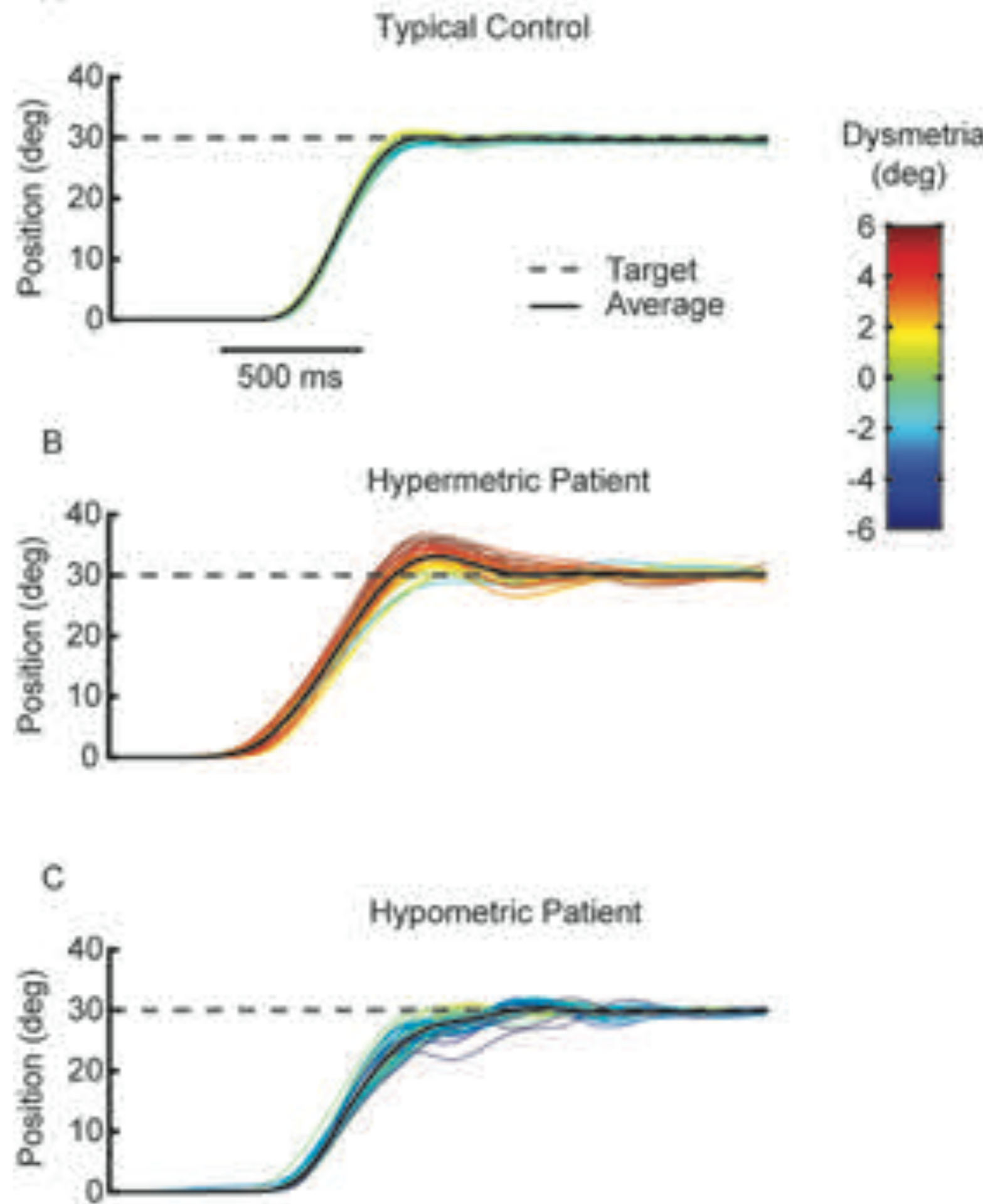
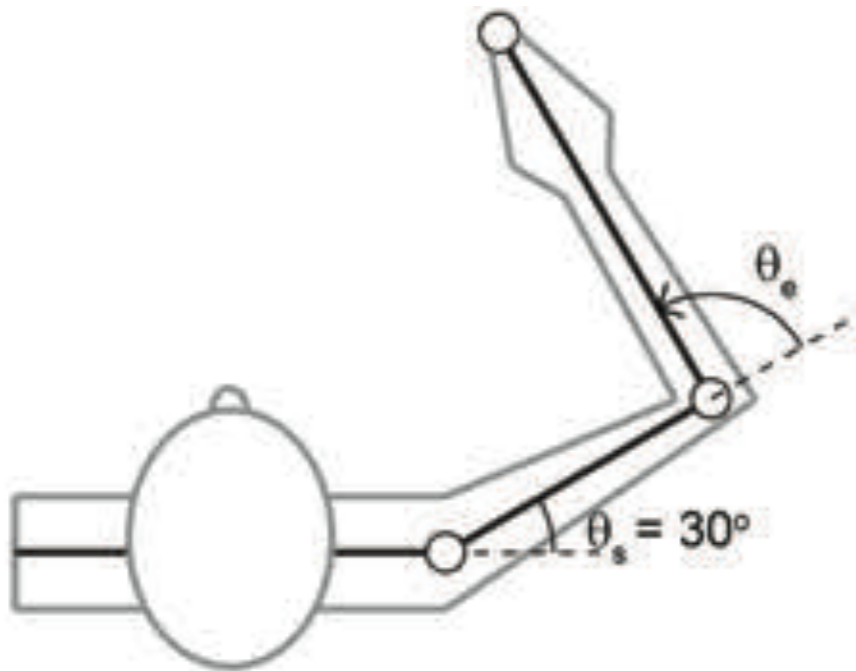

control perturbations

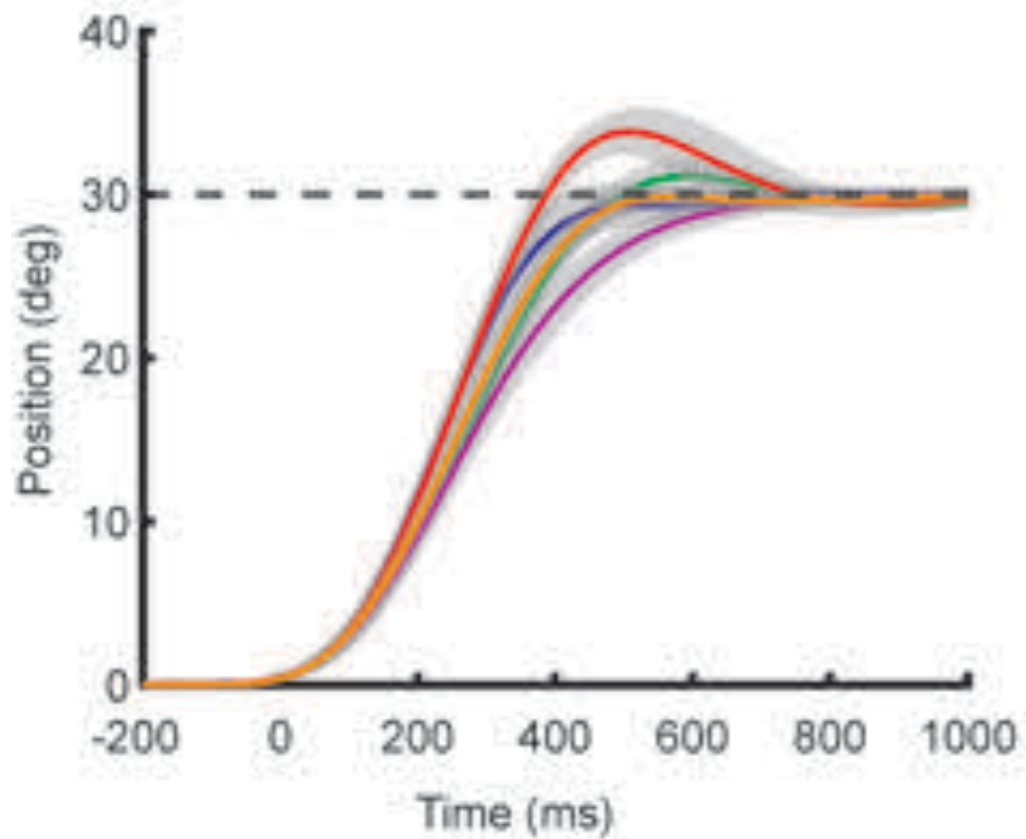

model

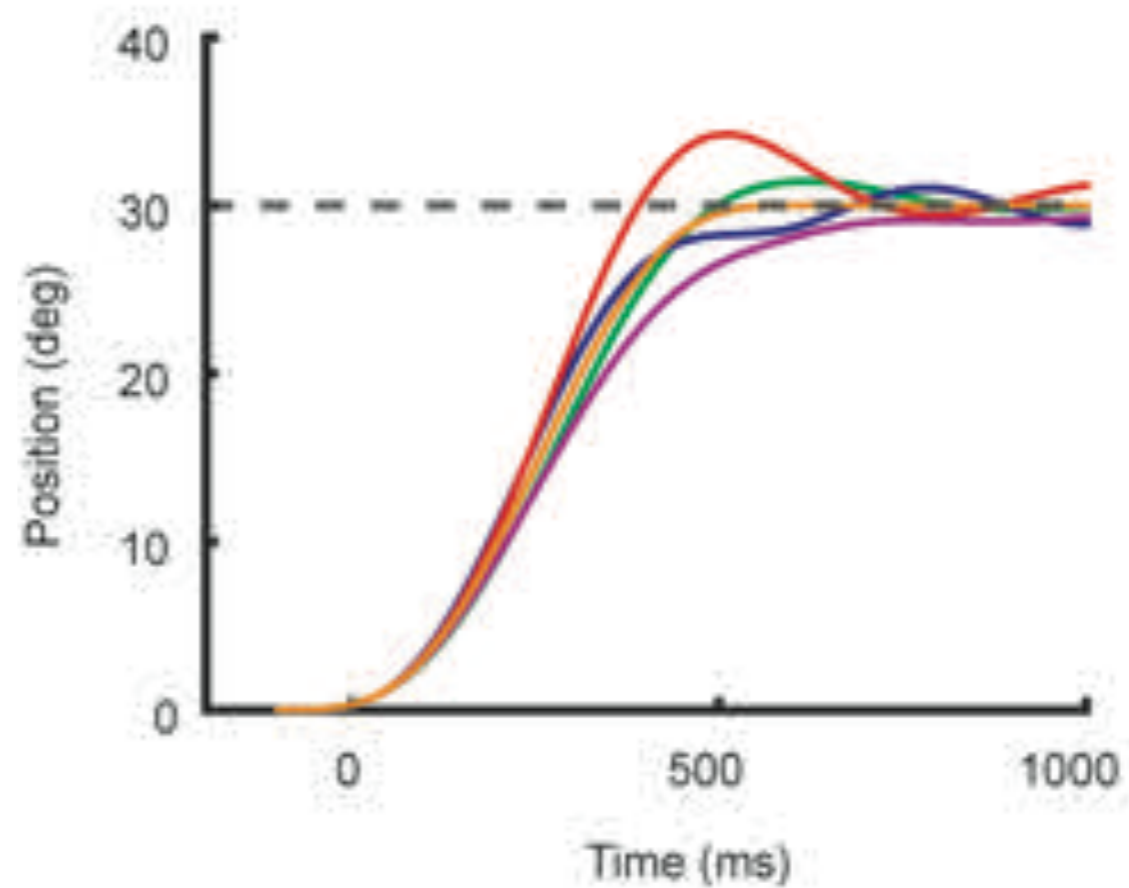

- Baseline
- Increased Inertia
- Decreased Inertia
- Increased Viscosity
- Decreased Viscosity
- - Target

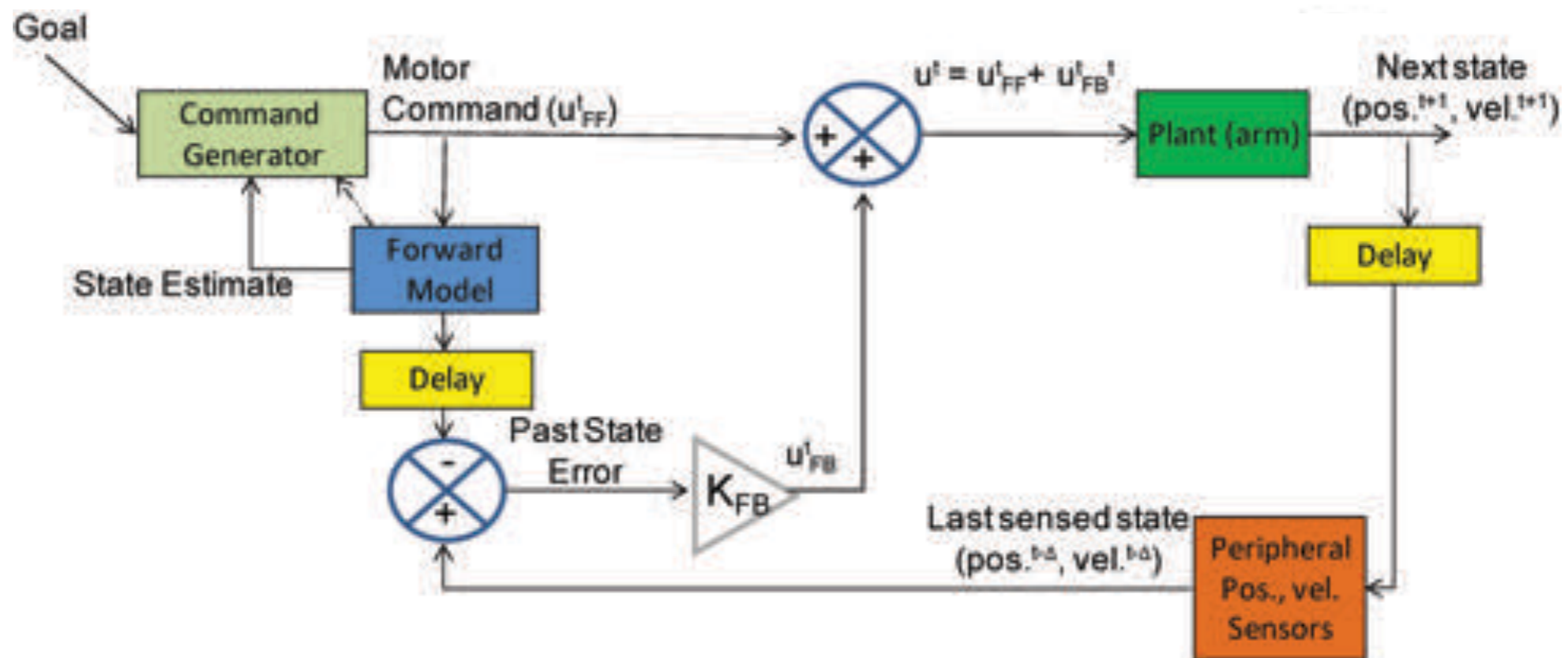

Internal model inertia bias determined by the computational model is highly correlated with dysmetria

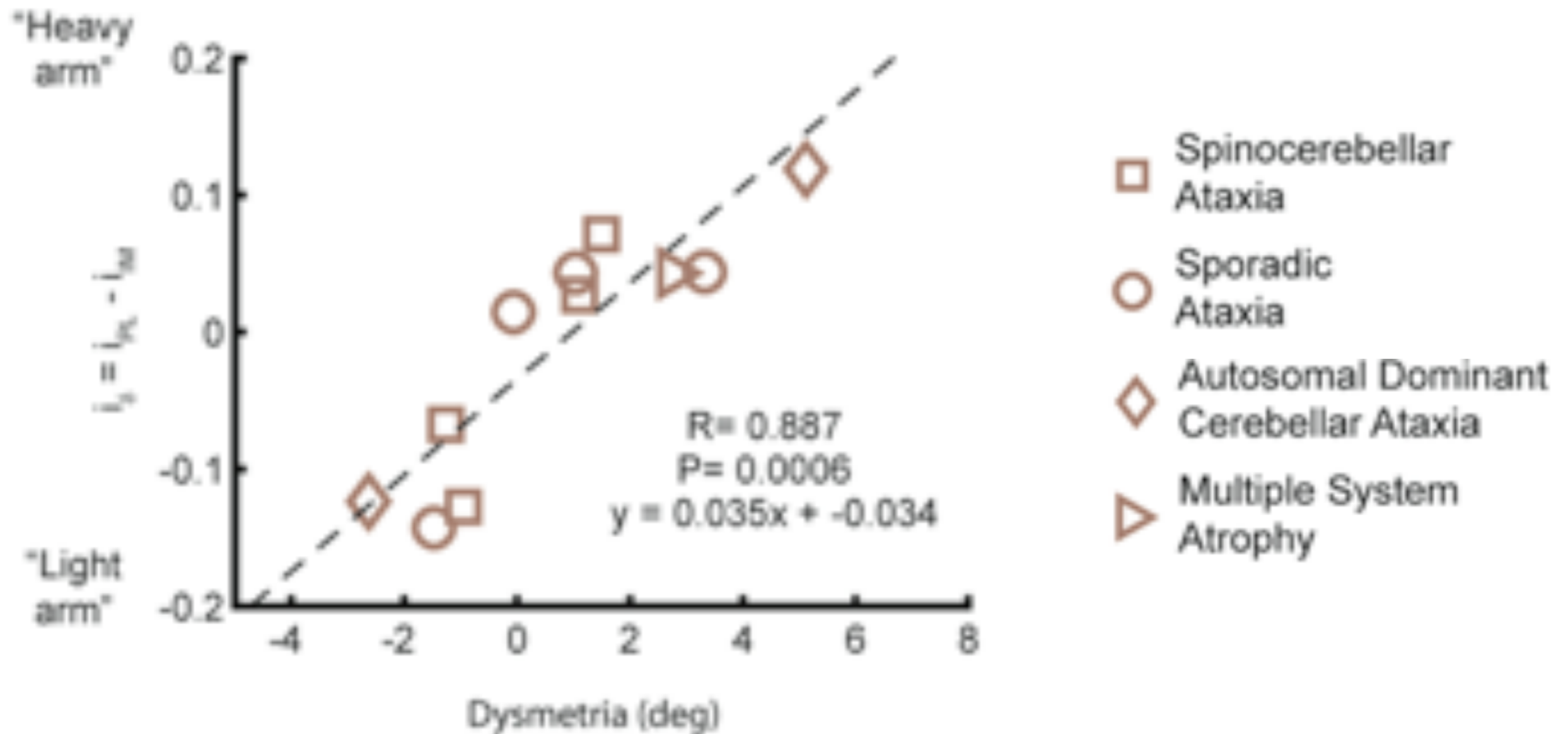

Implement compensation

force = mass * acceleration

Here, mass can be positive or negative!

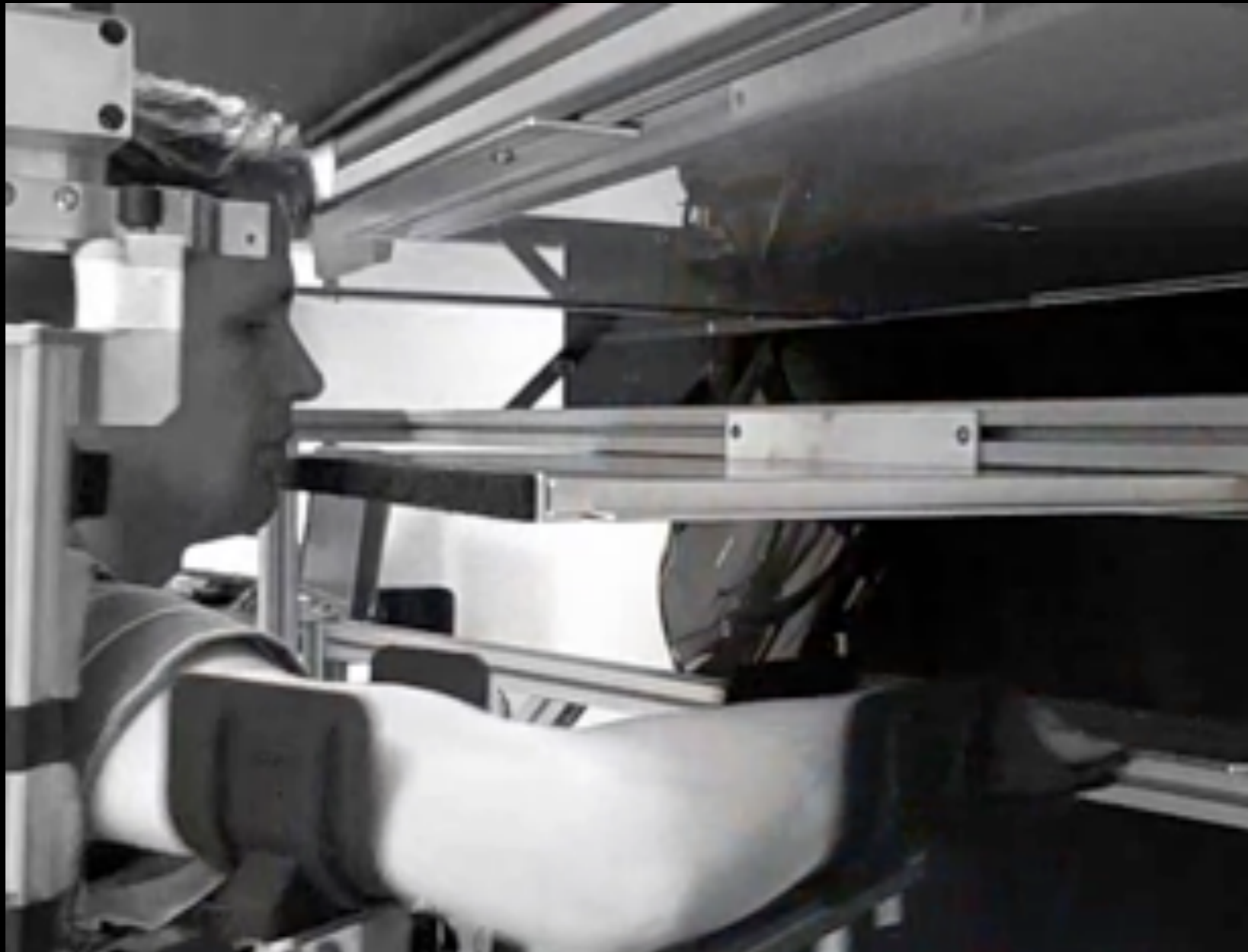

Results of robot intervention

If a patient has **hypermetria**,
use the robot to
decrease their inertia

If a patient has **hypometria**,
use the robot to
increase their inertia

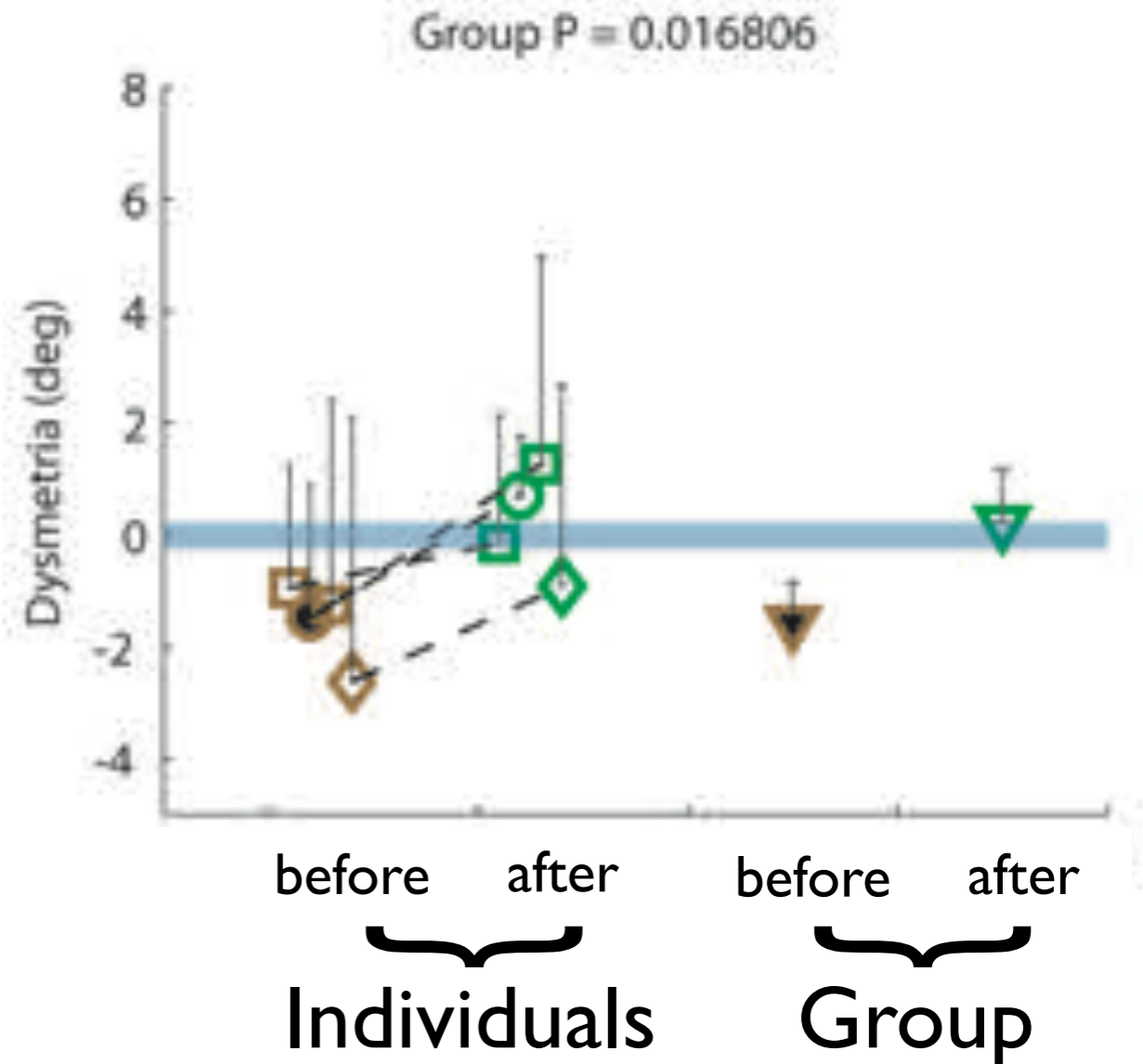
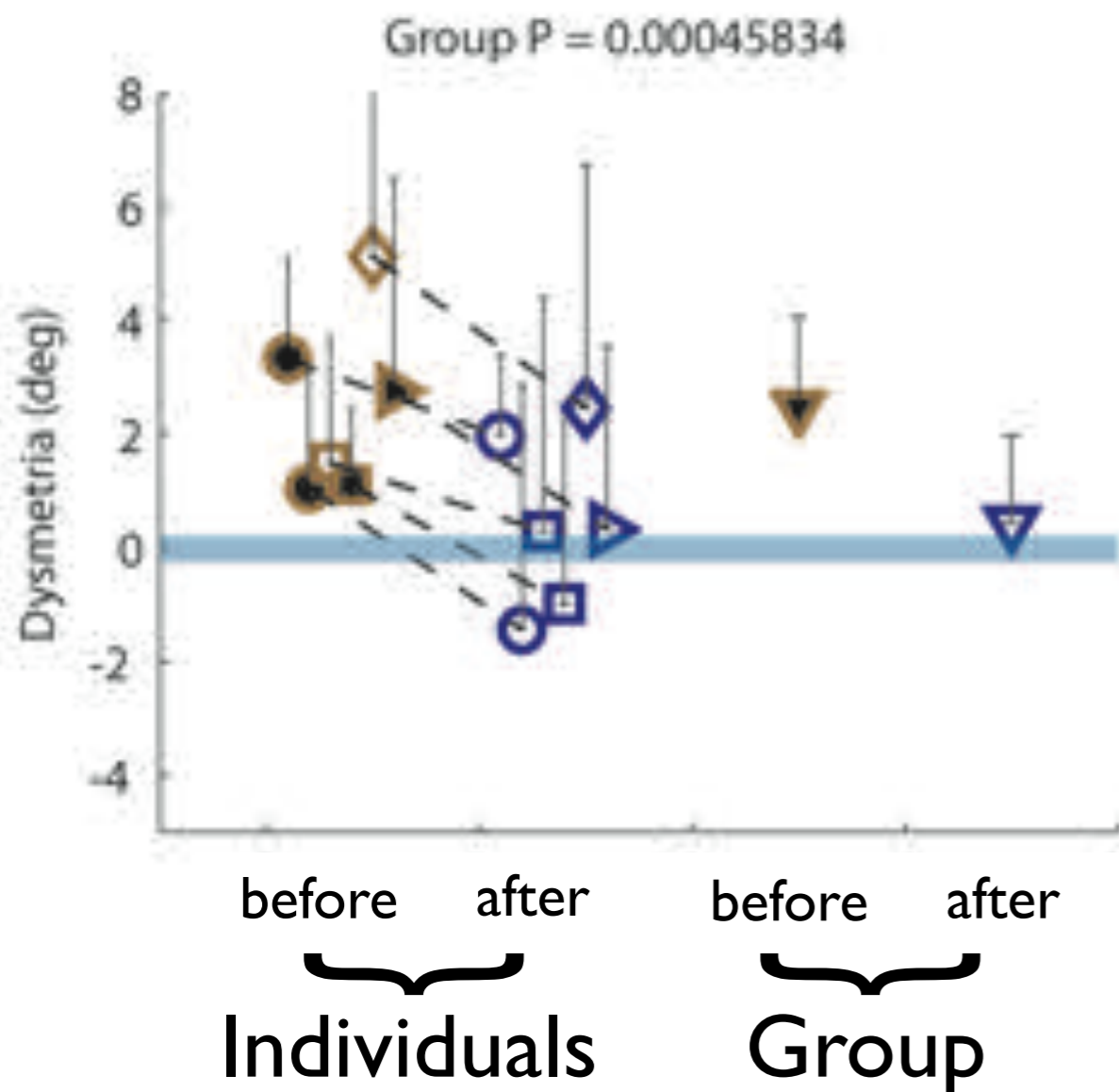

We find **patient-specific** biases in dynamics representation.

We can **replicate dysmetria** by creating a mismatch in dynamics (inertia) in healthy people *and* using simulation.

We can partially **correct dysmetria** by altering patient limb inertia with a robot. This does not correct trial-to-trial variability.